

6 LX&Maxi-Shear Series Micro-Shear® Flush Cutters

SERIES

Upgraded for the 21st century, the LX Series Micro-Shear® Flush Cutters are stronger and more durable with improved cutting capacity. These mid-range flush cutters feature precision-ground, ultra-sharp cutting edges on a tool designed for maximum strength and durability. State of the art heat treating to a Rockwell 55-57C ensures a rugged, precise, and extremely durable flush cutter capable of cutting soft leads up to 16 AWG (1.29 mm). Features also include ergonomic design, non-slip Xuro-Rubber™ grips, a glare resistant bright finish and our patented, lifetime warranted, *Light Touch™* return spring.

LX Series shears are optionally available with static control (AS) grips

2175 Maxi-Shear™ Flush Cutter

An extremely durable and versatile wire cutter featuring our patented Micro-Shear® cutting action. Tough enough for harnesses and cables with the precision to cut material less than 1 mil. thick or work in high density areas. Ergonomically shaped, non-slip Xuro-Rubber™ grips and a glare eliminating black finish ensure operator comfort. Non-protruding, lifetime warranted flat spring provides excellent "feel" without excessive spring tension. Flush cuts soft wire up to 12 AWG (2.05 mm).

LX Micro-Shear® Flush Cutter

Our patented Micro-Shear® cutting action combined with precision ground cutting edges, extra tough .100" thick high carbon steel blades, and an ultra slim profile for access in high density areas. Sized for smaller hands and maximum maneuverability. Flush cuts soft wire up to 16 AWG (1.29 mm).

LX-F Micro-Shear® Flush Cutter

Our LX with a factory installed lead retainer. Design provides a low profile and non-slip mounting on the shear. Helps prevent flying leads and component shorting from stray leads.

LX-T Micro-Shear® Flush Cutter

A special, extra tapered cutter head with an ultra-slim tip profile combined with the same Micro-Shear® cutting action, precision grinding, and tough high carbon steel blades of the standard LX. Ultra-sharp, precision tip for access in highly restricted areas. Flush cuts soft wire up to 20 AWG (0.8 mm).

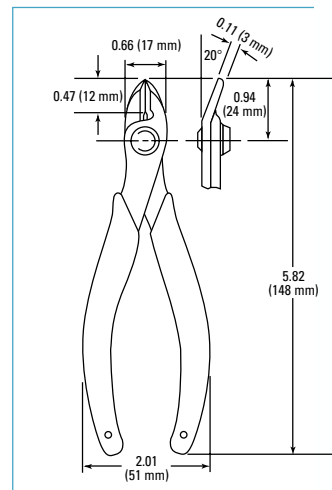
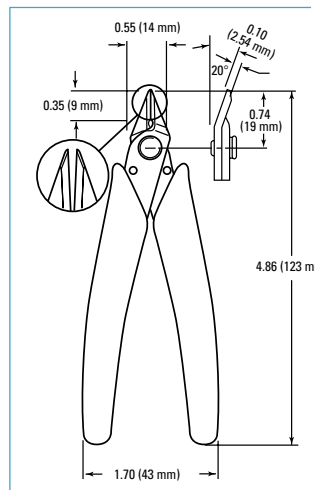
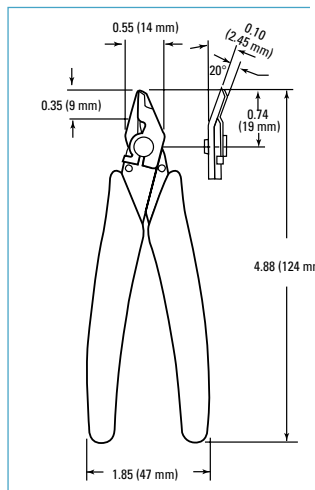
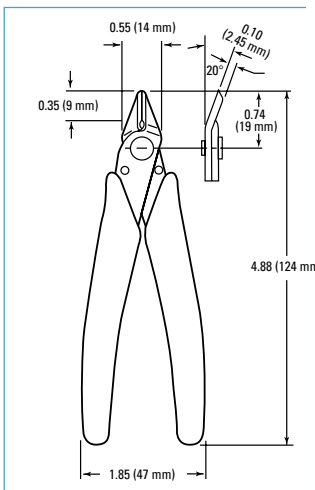

FEATURING QUALITY & PRECISION

LX&MAXI-SHEAR SERIES

LX&Maxi-Shear Series Micro-Shear® Flush Cutters 7

The 2175 Maxi-Shear™ Series flush cutters are manufactured from the highest grade, 0.125" high carbon steel. They feature our lifetime warranted, *Light Touch*™ return spring and ergonomically-shaped, non-slip Xuro-Rubber™ grips. Most important, all 2175 Maxi-Shear™ flush cutters utilize our patented Micro-Shear® cutting action. This means less cutting effort, less fatigue, and fewer fatigue-related injuries and complaints. Maxi-Shears™ are optionally available with static control (AS) grips.

2175A Maxi-Shear™ Flush Cutter

Ultra flush cutting version of our 2175 for fine work and very soft materials. Very lightly bevelled cutting edges allow for minimal blade by-pass (see diagram) ensuring the finest flush cut possible. Glare eliminating black finish and ergonomically-shaped Xuro-Rubber™ grips. Cuts soft wire up to 14 AWG (1.6 mm).

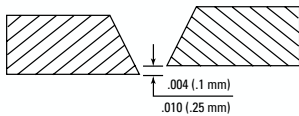

2175B Maxi-Shear™ Flush Cutter

Semi-flush cutting version of our 2175. A more pronounced bevel on the cutting edges (see diagram) allows for heavier cutting or extended wear where flush or ultra flush cuts are not required. Non-slip, ergonomically shaped Xuro-Rubber™ grips and a glare eliminating black finish for operator comfort. Semi-flush cuts on soft wire up to 12 AWG (2.05 mm).

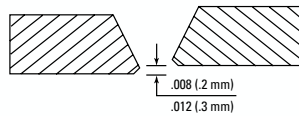

2193 Music Wire Shear

Large, full by-pass shear designed specifically for cutting music wire and other types of hardened wire. Shearing cut combined with high mechanical advantage make cutting iron, hardened and tempered steel wire up to 12 AWG (2.05mm) seem effortless. Cushioned Xuro-Rubber™ grips and our *Light Touch*™ return spring for operator comfort. Cuts music wire up to 0.040" diameter.

2193F Music Wire Shear

Our 2193 with self-adjusting clamping fixtures which hold the material being cut perpendicular to the cutter jaws. Greatly simplifies cutting process while adding significantly to both the precision of the cut and cutting capacity. Gives square ended cuts on both the cut and off-cut sides. Cuts music wire up to 0.060".



2175F Maxi-Shear™ Flush Cutter

Our 2175 with a factory-installed lead retainer. Clip is permanently installed for non-slip positioning. Low profile design for good sight lines and accessibility. Helps prevent flying leads and component shorting from stray leads.

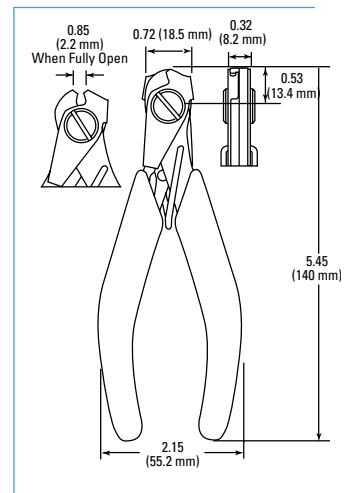
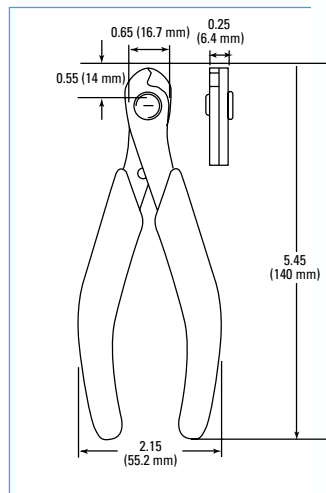
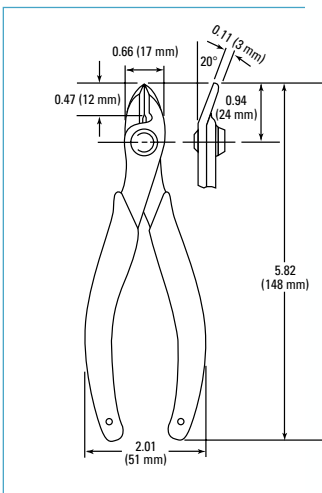

For a selection of companion pliers turn to Pliers section beginning on page 13